

## Adjustable Grooving Cutters. 3 + 3 Wing



### Application:

A two piece cutter which allows various widths to be obtained by use of spacers and shims. Can be used for **grooving and trenching operations** as well as **jointing and rebating**.

Both sides of head have seats for scribes, allowing LH & RH operation as required, producing sharp clean edges. **Recommended for mechanical feed**

### Sizes Available

CODE	D	d	W	Insert size	Insert size
SAG-1501018-1¼	150	1¼	10 - 18	9 x 12 x 1.5	14x14x2
SAG-1501426-1¼	150	1¼	14 - 26	12 x 12 x 1.5	14x14x2
SAG-1502242-1¼	150	1¼	22 - 42	20 x 12 x 1.5	14x14x2
SAG-1503262-1¼	150	1¼	32 - 62	30 x 12 x 1.5	14x14x2
SAG-1501018-40	150	40	10 - 18	9 x 12 x 1.5	14x14x2
SAG-1501426-40	150	40	14 - 26	12 x 12 x 1.5	14x14x2
SAG-1502242-40	150	40	22 - 42	20 x 12 x 1.5	14x14x2
SAG-1503262-40	150	40	32 - 62	30 x 12 x 1.5	14x14x2
SAG-15052102-40	150	40	52-102	50 x 12 x 1.5	14x14x2
SAG-1801018-1¼	180	1¼	10 - 18	9 x 12 x 1.5	14x14x2
SAG-1801426-1¼	180	1¼	14 - 26	12 x 12 x 1.5	14x14x2
SAG-1802242-1¼	180	1¼	22 - 42	20 x 12 x 1.5	14x14x2
SAG-1803262-1¼	180	1¼	32 - 62	30 x 12 x 1.5	14x14x2
SAG-1801018-40	180	40	10 - 18	9 x 12 x 1.5	14x14x2
SAG-1801426-40	180	40	14 - 26	12 x 12 x 1.5	14x14x2
SAG-1802242-40	180	40	22 - 42	20 x 12 x 1.5	14x14x2
SAG-1803262-40	180	40	32 - 62	30 x 12 x 1.5	14x14x2
SAG-18052102-40	180	40	52 - 102	50 x 12 x 1.5	14x14x2

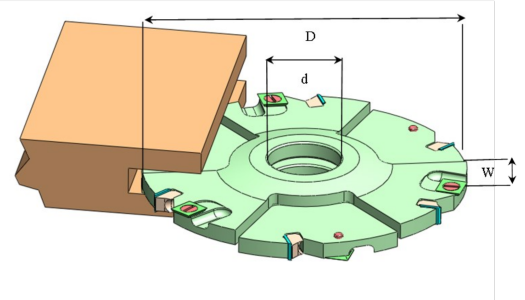

### Spare Parts:

Wedge	09 mm = W0912-TS-T3 10 mm = W1012-TS-T3 12 mm = W1212-TS-T3 20 mm = W2012-TS-T3 30 mm = W3012-TS-T3 50 mm = W5012-TS-T3
Scribes	14 x 14 x 2 Scribe
Scribe Screw	SS-M5-06 up to 10mm thick
Scribe Screw	SS-M5-09 up to 12mm thick
Scribe Screw	SS-M5-12 over 12mm thick
Screws	M5 x 16 TH. M6 x 16 TH.
Key	4A/F-TEE
Key	5A/F-TEE

## Adjustable Trenching Heads 3 + 3 Wing

### Application:

Specifically designed for trenching operations, on house frame top and bottom plates, using suitable docking saws. Also can be used on general trenching and grooving operations on all types of spindle moulders.

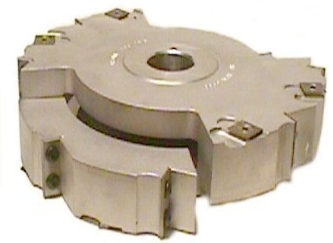
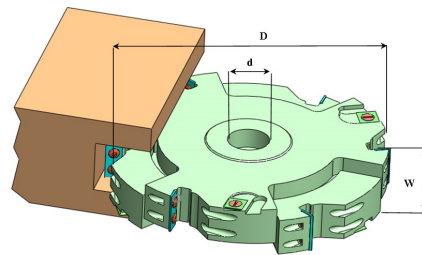

A wide range of bushes are available to suite all types of trenching and docking machines .  
ALL TOOLS COME WITH BUSHES

A

### Sizes Available

CODE	D	d	W	Insert size	Insert size
SATH-200-2242-30	200	30	22-42	20 x 12 x 1.5	14x14x2
SATH-200-3262-30	200	30	32-62	30 x 12 x 1.5	14x14x2
SATH-250-2242-30	250	30	22-42	20 x 12 x 1.5	14x14x2
SATH-250-3262-30	250	30	32-62	30 x 12 x 1.5	14x14x2

### Spare Parts:

Wedge	W2012-TS-T3 W3012-TS-T3
Screw	M5 x 12 -TH M6 x 16 -TH
Scribe	14 x 14 x 2 Scribe
Scribe Screw	SS-M5-12
Key	4AF-TEE 5AF-TEE